

# INSTRUCTION MANUAL

## AMS 500 One Piece Negative Pressure Unit (AMS-500 NPU 230V)

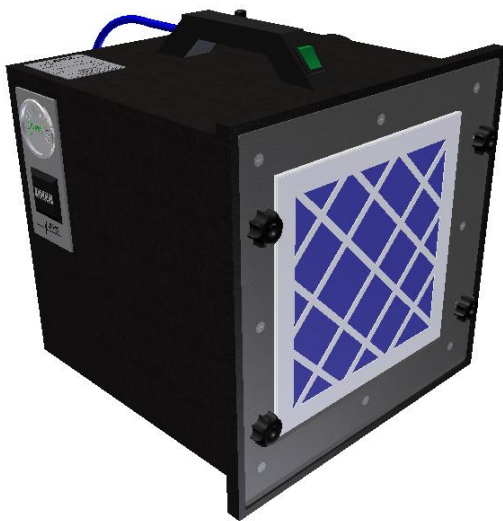



# WARNING

Asbestos exposure can cause severe and fatal diseases. Approved Code of Practices should be applied at all times when using this equipment to ensure safe working conditions.

Manufactured by:

## **Air Management Systems Ltd**

Unit 1  
9 Cannon Lane  
Tonbridge  
Kent  
TN9 1PP

Tel: +44 (0) 1732 368359  
Fax: +44 (0) 1732 368361  
Web: [www.ams-holdings.com](http://www.ams-holdings.com)

### **About this Manual:**

The purpose of this manual is to enclose all relevant information and data to this particular product and related uses. This manual is to be utilised by the user of this product to ensure correct and safe methods are used during related operations.

**All Rights Reserved ©**

Contents of this manual are not be copied or distributed by anyone without permission of the manufacturing company of this product.

## Table of Contents

<b>1. Description and Data</b> .....	<b>5</b>
1.1 General Description .....	5
1.2 Technical Data.....	7
1.3 Airflow Performance.....	7
<b>2. Installation</b> .....	<b>8</b>
2.1 Power Requirements .....	8
2.2 Positioning & Location of NPU .....	8
2.3 Fixing & Installation of NPU .....	8
<b>3. Operation</b> .....	<b>11</b>
3.1 Preparatory .....	11
3.2 Start up .....	11
3.3 Normal Running Checks .....	11
3.4 Shut Down .....	11
<b>4. Safety Procedures</b> .....	<b>12</b>
4.1 General.....	12
4.2 Handling.....	12
4.3 Transportation.....	12
4.4 Storing .....	12
<b>5. Maintenance</b> .....	<b>13</b>
5.1 Periodical.....	13
5.2 Preventative Maintenance.....	13
5.3 Replacing Filters .....	13
5.3.1 Pre-Filter Change Description.....	13
5.3.2 Illustration of Pre-Filter Change .....	14
5.3.3 HEPA Filter Change Description.....	15
5.4 Fault Finding .....	15
<b>6. Equipment to be Serviced</b> .....	<b>15</b>
<b>7. Spare &amp; Accessories</b> .....	<b>16</b>

7.1	Recommended Spares and Service Components.....	16
7.2	Optional Extras .....	16
<b>8.</b>	<b>Technical System Information .....</b>	<b>17</b>
8.1	Wiring Diagram .....	17

# 1. Description and Data

## 1.1 General Description

**AMS** manufacture a range of “Negative Pressure Units” (NPU’s) to provide a powerful filtered air extraction system. The NPU’s are mobile, easy to handle, install and operate. All NPU’s are manufactured from durable, robust, safe and easy to clean materials.

**AMS** NPU’s are mostly used in the Asbestos Removal Industries in Europe and other countries around the world that apply regulations to safely remove asbestos. The equipment is also used in other industries to control environments where air contamination is a problem, including the nuclear industry.

NPU’s are normally attached to a contained area (working enclosure) that is likely to become contaminated during the maintenance or removal work. Extraction of filtered air will provide “Negative Pressure” in the contained area preventing contamination to adjacent areas. In Europe and in other parts of the world it is a regulation to use this equipment during the removal of asbestos materials.

**AMS** are specialist manufacturers of NPU’s and other equipment used for the European asbestos removal industry. All equipment is manufactured to recognised European standards as well as adapted for the specific local requirements of a particular country.

The **AMS** 500 NPU provides a nominal airflow of 750 m<sup>3</sup> / hour depending on HEPA filter arrangement.

The NPU (AMS-500) contains the following main components:

- Main Case Enclosure
- Electric Motor Fan
- Pre-filter
- HEPA Filter
- Operation Control Instrumentation
- Pressure Difference Indicator (manometer)

For Optional Extras please refer to Section 7 of this manual

The NPU case is constructed from welded polypropylene, reinforced with welded polypropylene internal ribs. Critical joints are ‘triple-welded’. Non-return flaps are fitted on the exhaust and the Basic Unit has an On/Off Switch, a Speed Controller and a Pressure Drop Indicator (manometer).

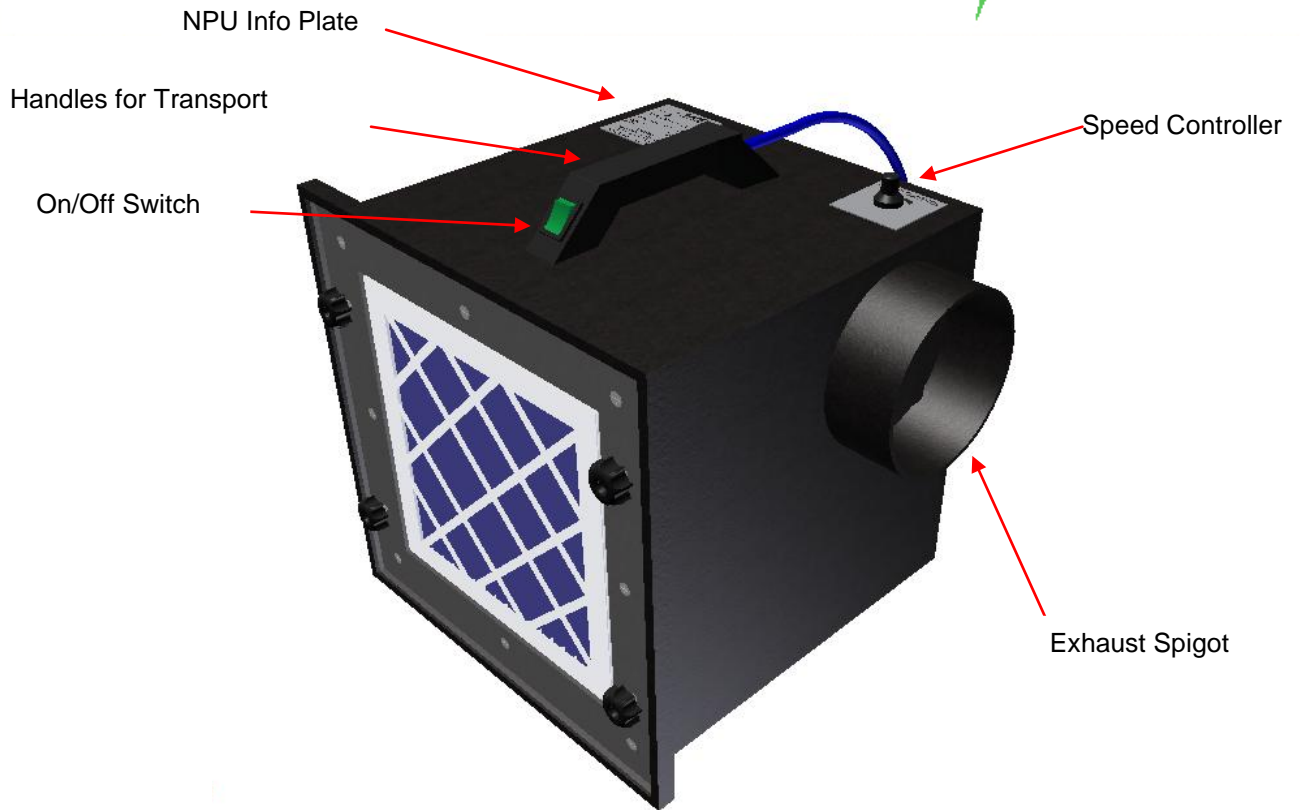

**Figure 1.1 – NPU Control & Monitor Components**

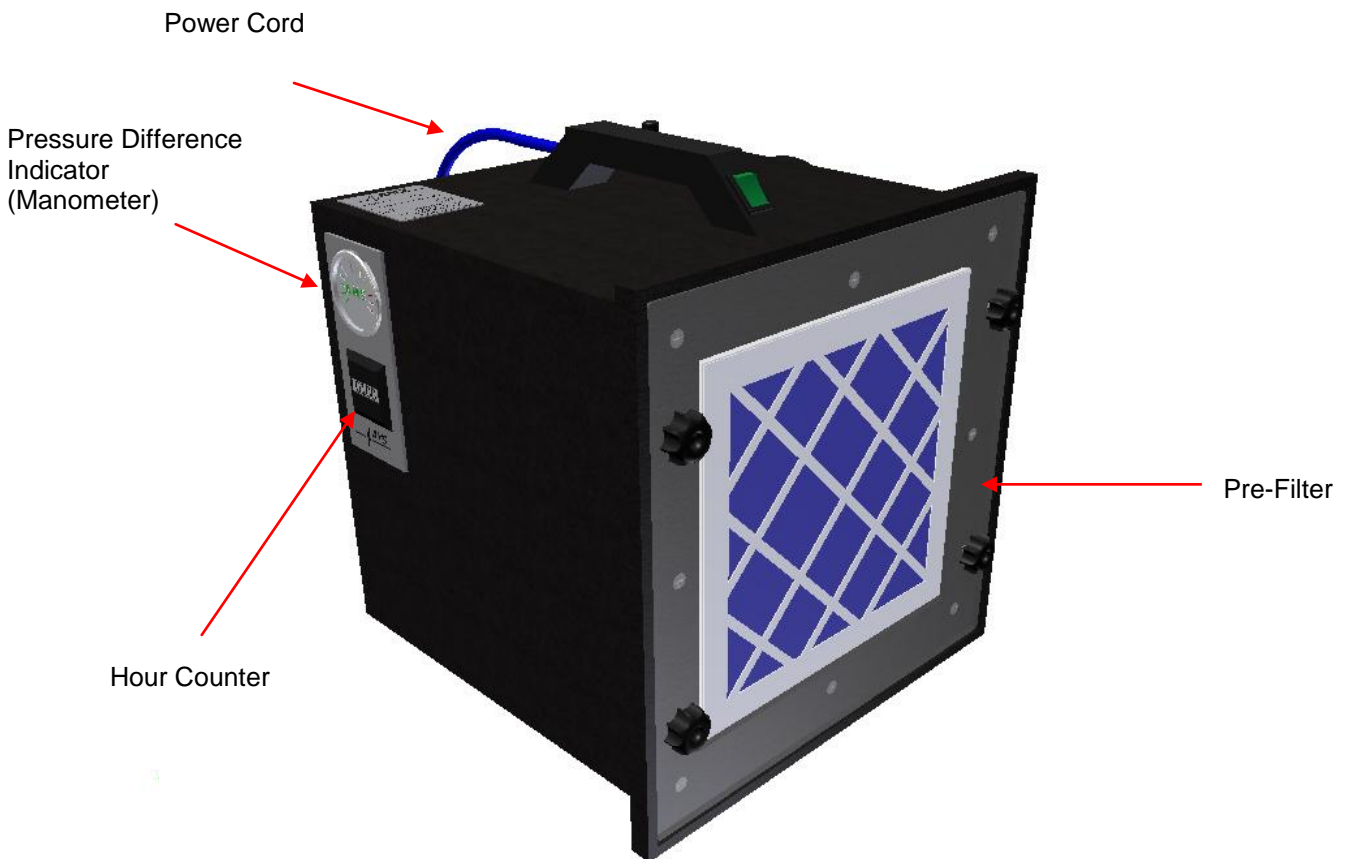

**Figure 1.2 – NPU View of Exhaust Spigot**

## 1.2 Technical Data

<b>AMS-500 NPU</b>	
<b>Supply Voltage</b>	230v @ 50Hz
<b>Current</b>	1.2A
<b>Motor Output</b>	273w
<b>RPM</b>	2110
<b>Temperature Range</b>	-20 to +40 °C
<b>Controls</b>	On/Off Switch and Speed Control
<b>Protection</b>	Inbuilt thermal cut-out with automatic reset
<b>Air Flow rate (H14 HEPA FILTER)</b>	750m <sup>3</sup> / hour
<b>Dimensions:</b>	
<b>Height</b>	485 mm
<b>Width</b>	470 mm
<b>Length</b>	385 mm
<b>Weight</b>	19kg
<b>Pre-filter Size</b>	292 mm x 292 mm x 47 mm
<b>Pre-filter Efficiency</b>	EU4
<b>HEPA Filter Size</b>	305 mm x 305 mm x 117 mm
<b>HEPA Filter Efficiency (H14)</b>	99.995%
<b>Ducting Connection Size</b>	170 mm diameter

## 1.3 Airflow Performance

Airflow ratings for this particular NPU can be found in section 9 within the test report.

When exhaust ducting is used the following considerations should be made:

- If flexible ducting is used on the exhaust to a length of 5 metres in a straight line, air flow will not be impaired.
- Any length of flexible ducting above this criterion will result in reduced flow performance and appropriate adjustments are recommended.
- Typical airflow losses of 0.05-0.07 m<sup>3</sup> per 6 meter length of ducting should be considered.
- It is recommended that the Pre-filter is changed at regular intervals to optimise the performance of the Negative Pressure Unit. Regular inspections must be carried out before, during and after use by competent, trained personnel.
- When the reading on the 'manometer' increases, this could indicate that the Pre-filter may require changing. If this reading remains relatively high with a clean Pre-filter, this could indicate that the HEPA Filter requires changing. We would recommend that the HEPA

Filter is tested by an approved service centre at this stage. All type of filter changing is required to be done under controlled conditions.

## 2. Installation

### 2.1 Power Requirements

The AMS-500 utilises an electric motor fan to generate the reduced enclosure pressure and must be connected to a power supply capable of 1.2A continuous current draw. The 230V Negative Pressure Units are supplied with a 5 metre fixed lead.

### 2.2 Positioning & Location of NPU

Considerations should be made to which location the unit will be installed.

- The NPU should be located outside of the enclosure at all times
- The NPU should be positioned on a sturdy base to avoid unwanted movement of unit, which could damage or break the seal between the NPU and enclosure.
- Consider exhaust ducting path if needed before connecting the NPU to enclosure.
- The unit shall be located in dry conditions, away from any water penetration or damp environments, to avoid the unit or any of its components becoming wet.
- The power supply cables should be run in a manner that does not create a tripping hazard and avoid locations where excessive traffic is present, which could result in unit damage or injury.
- The unit should not be located externally to any buildings ideally. If this cannot be avoided then the unit shall be located within a waterproof enclosure.

### 2.3 Fixing & Installation of NPU

THE NEGATIVE PRESSURE UNIT SHOULD NOT BE INSTALLED INSIDE THE ENCLOSURE

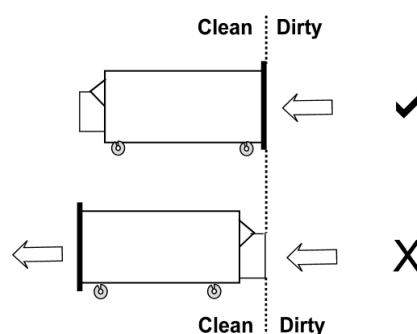

- FAILURE to comply will result in contamination of the NPU's clean side.



Example depicted in figure 2.1 – 2.3 applies to fixing and sealing a Negative Pressure Unit to a polythene enclosure. The Filter End of the NPU should be outside of the enclosure, with the inlet flange (Pre-filter inlet face) being taped to the polythene with cloth tape (refer to figures 2.2 & 2.3 to follow).

- Position the Filter End of the NPU against the inside or outside of the enclosure.
- Mark and cut a hole in the enclosure around the Pre-filter to accommodate the unit (figure2.2).
- Install the NPU against the opening and seal with conventional materials such as Polythene and Tape.
- Install the Pre-filter (pleats aligned vertically) and tape the edges to the enclosure to make a seal. The Pre-filter can then be changed without this seal between the enclosure and the NPU being disturbed.

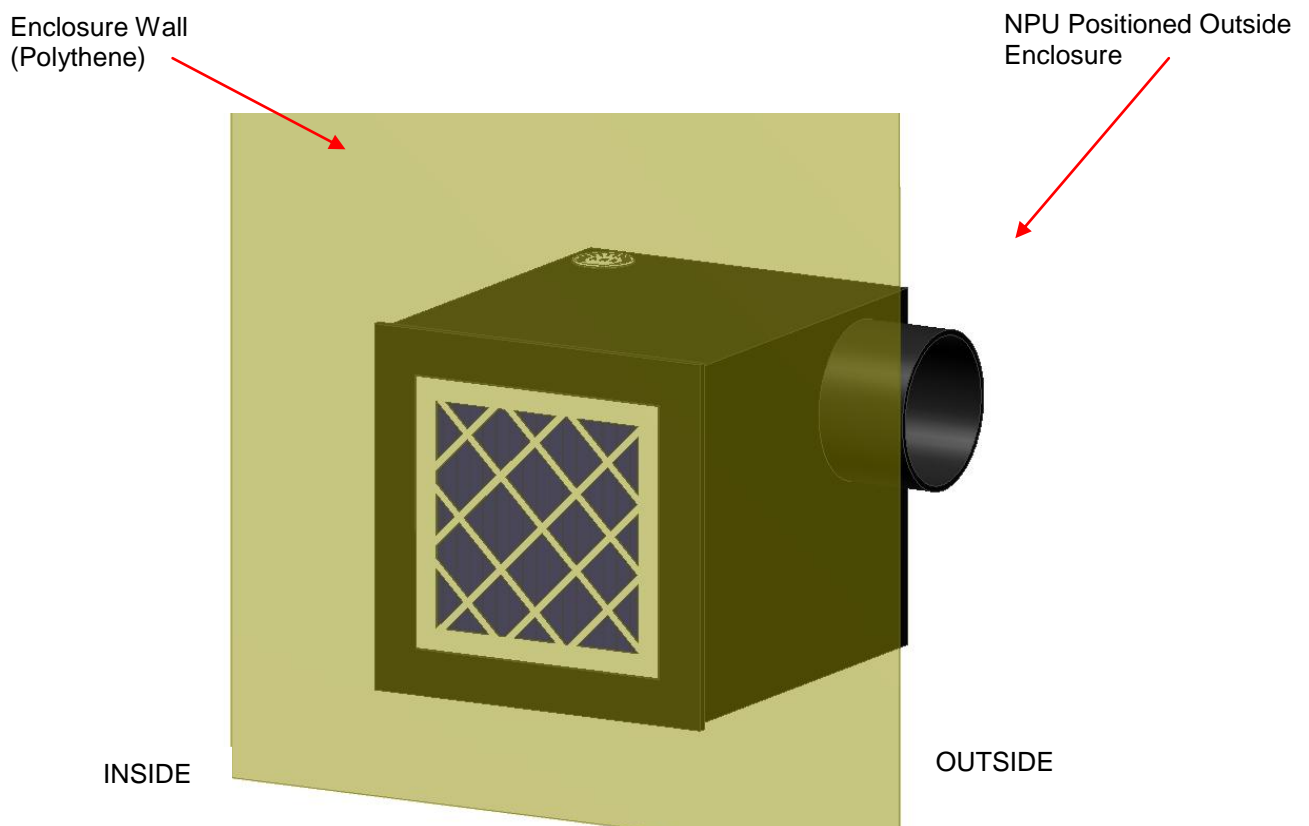

**Figure 2.1 – NPU Positioned Outside Enclosure**

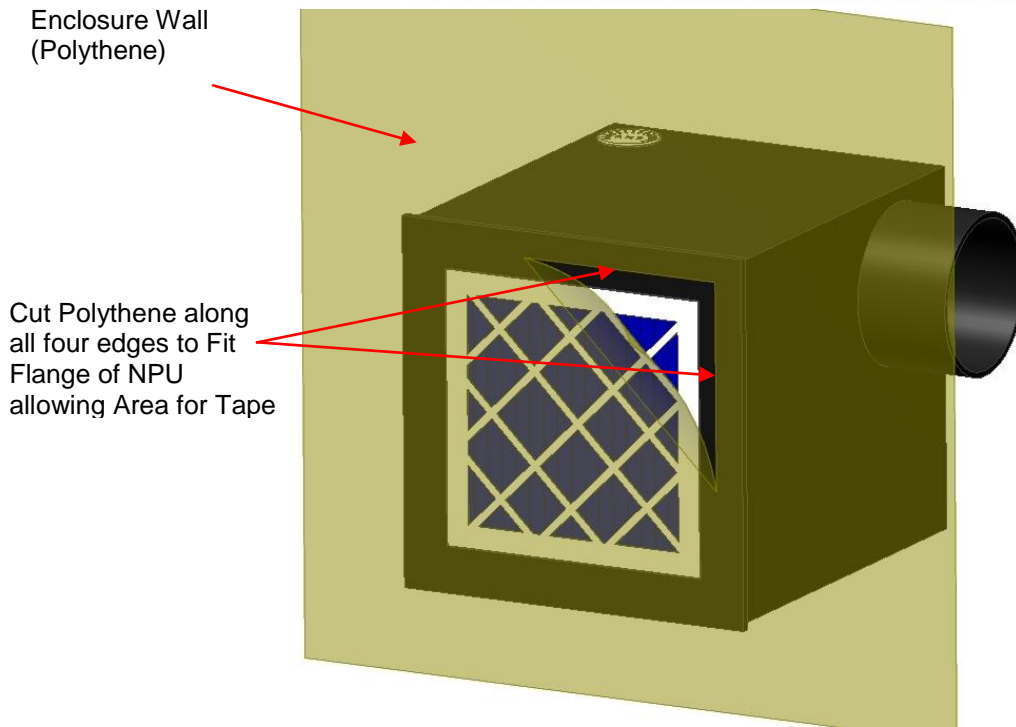

**Figure 2.2 – Hole Cut to NPU Flange Size**

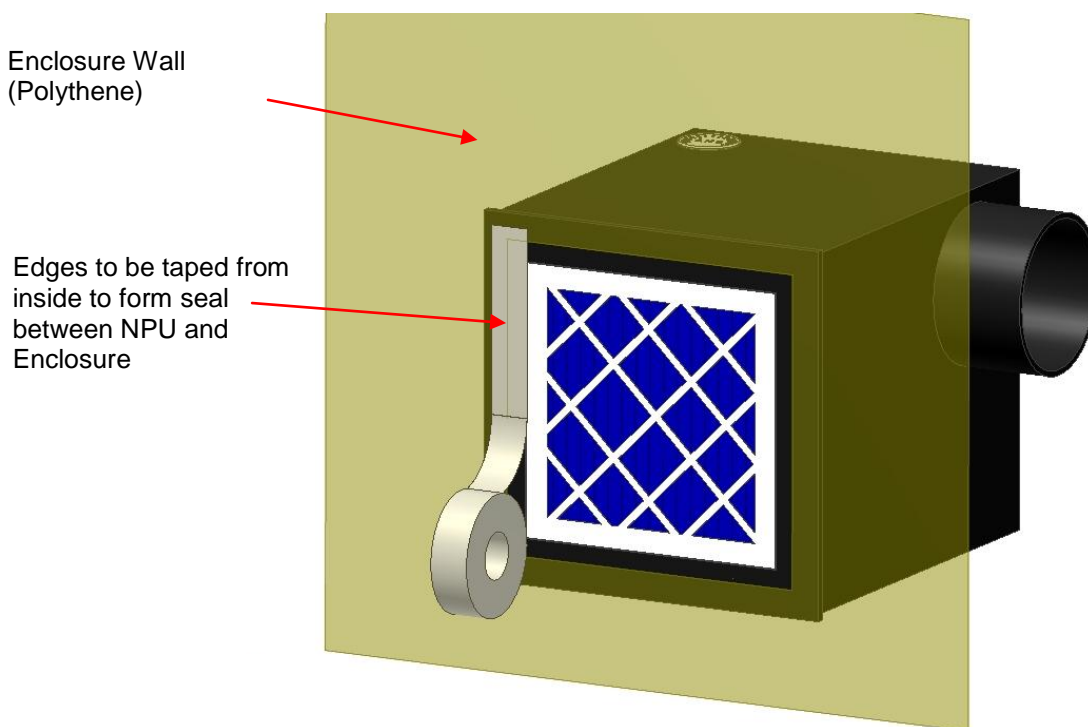

**Figure2.3 – All Four Edges to be Sealed via Tape**

## 3. Operation

### 3.1 Preparatory

The NPU should be operated under the supervision of competent and trained personnel.

- Ensure that the unit is correctly installed according to Section 2.
- Ensure that the enclosure is properly sealed to the Filter End of the NPU inlet face according to section 2.3.
- Ensure that the installed Pre-filter is the recommended type and the pleats are aligned vertically (section 2.3).
- Ensure that the NPU is switched off, prior to connecting to an appropriate power supply.

### 3.2 Start up

- Once the enclosure is complete and the NPU has been prepared, as detailed under section 3.1, turn the Speed Controller to its minimum setting.
- Switch on the fan motor
- Turn the Speed Controller clockwise until the required airflows achieved, if fitted.
- Note the reading on the manometer and record this as the initial reference level

### 3.3 Normal Running Checks

- Periodically check the pressure differential in the enclosure and adjust the Speed Controller accordingly.
- If negative pressure reduces cannot be maintained, check the manometer on the NPU to determine the efficiency of the filters. Check this new reading against the initial reference level. If there is no significant increase in the pressure differential there could be a leak in the enclosure. If there is a significant increase in the pressure differential then the filter system could be blocked and would need to be inspected.

### 3.4 Shut Down

- Switch the fan motor off via the switch on control panel.

## 4. Safety Procedures

### 4.1 General

- Power cables should be routed so that they do not create a tripping hazard.
- Whilst not in use, the Transit Cover Plate should be fitted to the NPU's Filter End.
- Whilst in use, the Pre-filter should be taped into place to prevent contamination ingress to the NPU.
- Check that the NPU has not been damaged in any way to ensure the integrity of the casing and components

### 4.2 Handling

The NPU must not be moved whilst in operation.

- The NPU must be moved with care and attention at all times to prevent damage.
- The NPU should only be moved by competent personnel
- You should consider the weight of the unit before deciding to move it and take all necessary precautions.

### 4.3 Transportation

- Prior to transporting the NPU ensure that either the transit cover has been located over the Pre-filter or a suitable seal has been achieved with polythene and tape.
- Whilst in transit, it is imperative that the NPU is secured, to minimise movement. This can be partially achieved by locking the braked castors, but further securing will be required.
- Care is to be taken to ensure safe handling whilst inserting and removing the NPU from the vehicle.

### 4.4 Storing

The NPU must be stored in a place that satisfies the following:

- Dry and damp free
- Internal temperatures between 0°C and 40°C
- In A Safe manner so as to prevent hazards to personnel
- Stacked on top of each other a maximum of one high
- All castors should be locked on the NPU

This list is not exhaustive and common sense must prevail.

## 5. Maintenance

### 5.1 Periodical

- D.O.P testing and Inspection should be carried out every 6 months.
- It is recommended to use authorised centres only.

### 5.2 Preventative Maintenance

- Keep the NPU clean and dry.
- Periodically check the condition of the power lead and keep in good condition.
- Check the manometer reading against the initial reference level
- Ensure that all personnel comply with your own filter change regime

### 5.3 Replacing Filters

#### 5.3.1 Pre-Filter Change Description

- Carefully remove tape from the dirty Pre-filter, remove the Pre-filter from the aperture and seal it in an approved asbestos waste bag.
- All types of filter changing are required to be done under controlled conditions while using appropriate Personal Protective Equipment.
- From NPU installation (section 2) the seal between the NPU and polythene sheet should still exist after Pre-filter has been removed. The new filter can now be inserted and must be sealed to the NPU via cloth tape.
- Also refer to NPU installation to aid understanding of process.

Replace the Pre-filter with an approved replacement, installing it with the pleats vertical & seal to NPU flange with tape

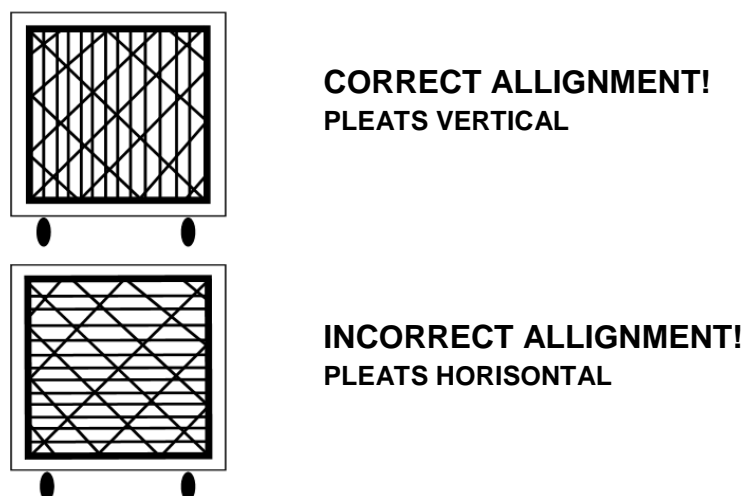

**Figure 5.1 – Illustration of Pre-filter Pleat Alignment.**

## 5.3.2 Illustration of Pre-Filter Change

(Example illustrates filter change of new and clean machine. PPE should always be used during filter changes)

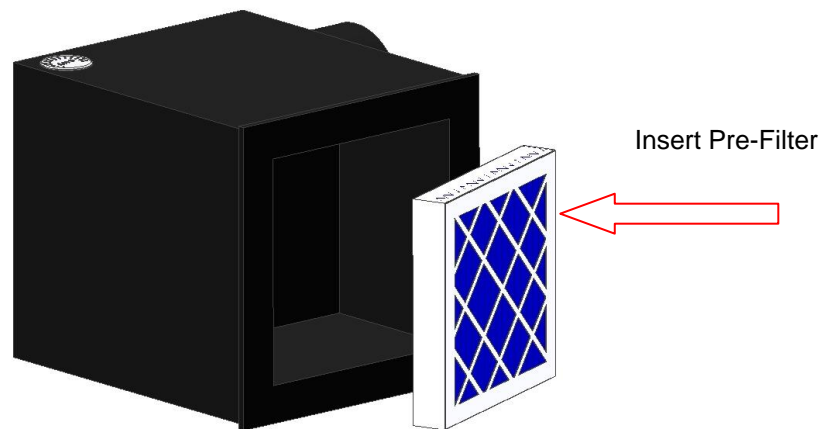

Figure 5.2 – Installation of Pre-Filter

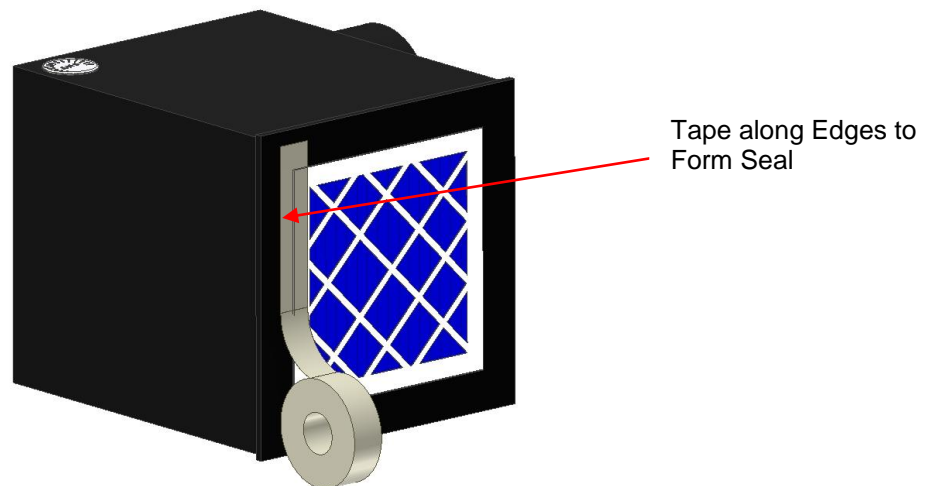

Figure 5.3 – Taping of Pre-Filter to form Seal

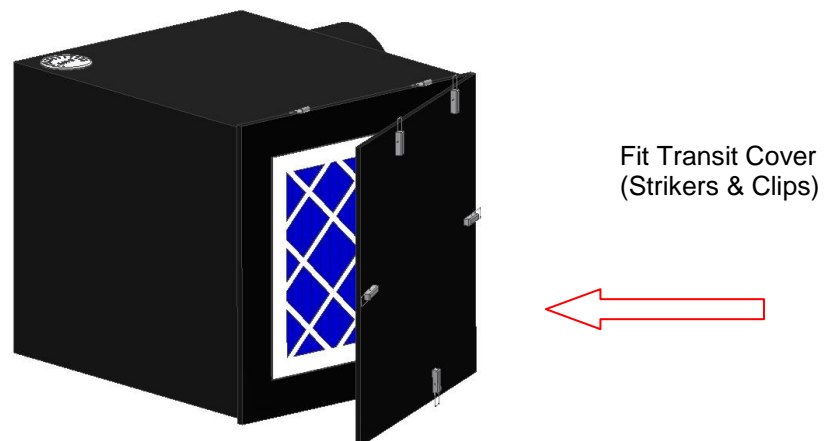

Figure 5.4 – Installation of Transit Cover

### 5.3.3 HEPA Filter Change Description

- Under no circumstances can the HEPA filter be changed whilst operational and in situ.
- All HEPA filter changes must be undertaken by qualified and competent service engineers under fully controlled conditions.

### 5.4 Fault Finding

Problem	Initial/Action	Fault	Further Action
NPU not operational	Check power supply is available and the unit is turned on	Faulty Fan or Electrical component	Call Service Engineer
Cannot maintain Negative Pressure	Check Manometer against Initial Reference Level reading	Pre-filter may be blocked	Replace Pre-Filter
		HEPA Filter may be blocked	Call Service Engineer
		Enclosure has Leak	Seal all leaks to Enclosure
No reading on pressure indicator (Manometer)	Check if Unit Operational	Gauge Faulty	Call Service Engineer
Speed Controller is not operational	Switch On/Off	Controller Faulty	Call Service Engineer

## 6. Equipment to be Serviced

- Before despatching for Service ensure that the NPU is suitable for movement, refer to Section 4 of this manual
- All equipment to be despatched for Service must be clean and free from any contamination
- Liaise with the Service Engineer for collection/delivery

## 7. Spare & Accessories

### 7.1 Recommended Spares and Service Components

- Pre-filters to recommended standards.
- Flexible Ducting, either aluminium foil or PVC.

Extension Pre-Filter box

### 7.2 Optional Extras

In addition, the following optional extras can be supplied, these would have to be factory fitted at the NPU's next service or supplied when new.

- Hour Counter
  - o Allows the monitoring of a unit's processing time and could be used to determine when filter change is likely.
- Residual Current Device
  - o A safety device that cuts the power supply when an electrical short circuit occurs within the system.
- Extension Pre-Filter Box
  - o An additional pre-filter box connected to the NPU by means of flexible ductwork to allow the air intake of the unit to be located to suit site conditions.
- Alarm Socket
  - o Alarm that sounds when power supply to NPU fails. Backup batteries allow alarm to function during power cut.
- Remote alarm Device
  - o An audible and visual alarm indicator to be connected to the Alarm socket
- Remote Device Power Outlet
  - o A power outlet to be used for other appliances or tools (to correct power rating).



## 8. Technical System Information

### 8.1 Wiring Diagram

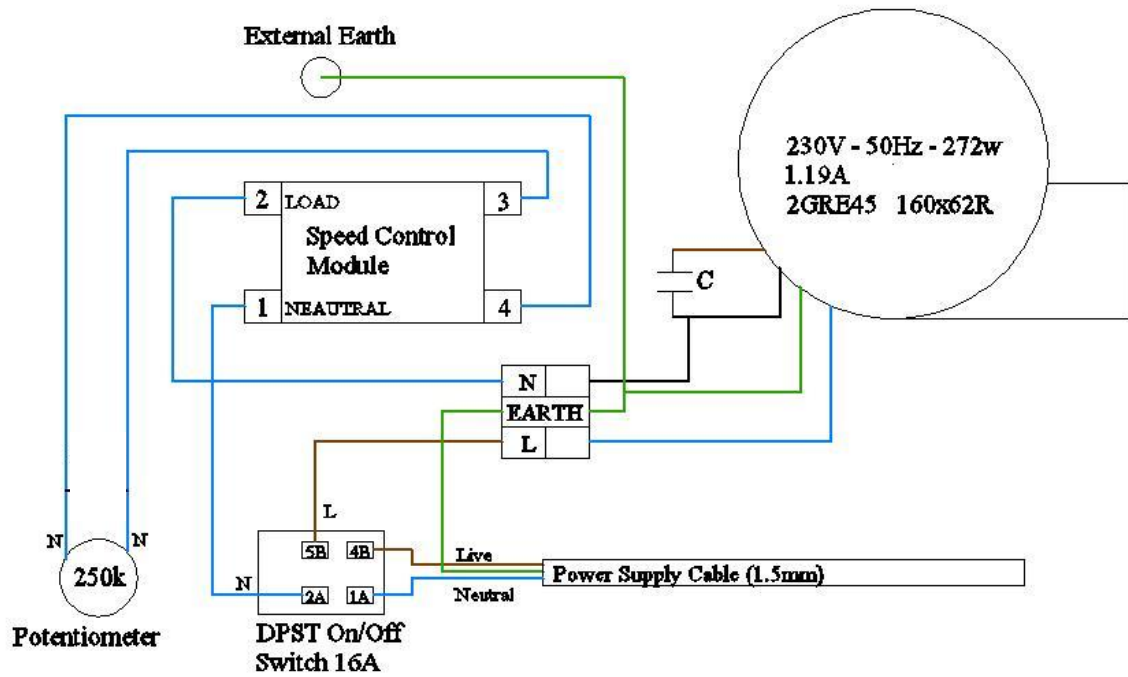

Figure 8.1 – Wiring Diagram for AMS-500 NPU

## 9. Test Reports

	NPU1	NPU2	NPU3	NPU4	NPU5	Maximum Airflow  Performance (m <sup>3</sup> /h)
Serial No	20145	20147	20150	20153	20236	
Manometer Reading	450	450	450	450	450	
Skirt Area m <sup>2</sup> (A)	0.09	0.09	0.09	0.09	0.09	
Average Face Velocity m/s (Y)	2.35	2.36	2.29	2.3	2.32	
<b>Calculation:</b>						
	+	+	+	+	+	/ 5 =
Y = A x 3600 x	763	766	744	746	752	<b>754</b>
	Total:				3771	
<b>Model Tested: AMS-500 NPU One Piece</b>			<b>Anemometer Type:</b>			
<b>Tested By:</b>  Air Management Systems Ltd Unit One, 9 Cannon Lane Tonbridge, Kent, TN9 1PP			<b>Engineer:</b>  Mark Goulding			
<b>Test Date:</b>  17/12/2014			<b>Engineer Signature:</b>  <i>M Goulding</i>			